



MULTI SCREEN® MS3200



ON A GREEN MISSION

soil



construction waste



green waste



wood chips



sand & gravel



recycling



stones



compost

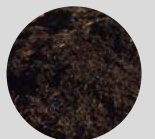

Illustration may contain extra charge options. All details are subject to technical modifications and future developments. Further distribution and any kind of publication is permitted only with written approval of the Zemmler Siebanlagen GmbH.



MULTI SCREEN® MS3200

OPTIONS



Bisection of the inner trommel approx. 75 x 75 mm

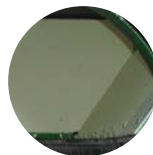

Abrasion plates for the silo



Outer wire screens 2 to 80 mm



Rear conveyor belt for coarse fraction



Inner wire screens optional 40 to 80 mm

MORE OPTIONS



Remote control



Extension for 3rd fraction; punched Ø 40 / Ø 50 mm or not-punched



Ripped belt for feeder or fine fraction



Remodeling on skids



Foldable hopper walls



Remodeling to hook lift



Chute for 3rd fraction



Flood lamps



Extension for feeder



Diesel power generator 17,0 kVA 14,4 kW



Extended conveyor belts



MULTI SCREEN® MS3200

TECHNICAL DESCRIPTION 1

Base frame:

longitudinal beam: hollow profile, height 180 mm
 chassis: 2 x 5,5 t air suspension
 product: BPW
 tires: 4 x 235/75 R17.5
 rim: 4 x 6,75 x 17.5
 brake: drum air break EBS-control unit (ABS)

Feeder:

cubage: approx. 2,3 m³
 loading height: 2,500 mm
 loading length: 3,050 mm

Feeding belt:

belt width: 800 mm
 belt length: 2,770 mm
 belt type: plain
 speed: adjustable
 profile belt: optional

Double trommel:

surface:
 inner: 8.1 m²
 outer: 10.0 m²
 drum diameter: 1,000 mm (inner)
 drum diameter: 1,300 mm (outer)
 drum length: 3,000/ 3,900 mm

Trommel drive: direct over chain and chain wheel

Mesh sizes:

inner: 75 x 170 mm (standard)
 outer: optional - exchangeable wire screens 2 - 80 mm

Cleaning brush:

diameter: 350 mm, with own drive

Conveyor belt fine fraction:

belt width: 600 mm
 Y-profile belt
 mechanic foldable
 drop off side: left
 drop off height: 1,970 mm (standard)
 2,775 mm (extended conveyor belt)

Conveyor belt middle / coarse fraction:

belt width: 600 mm
 Y-profile belt
 mechanic foldable
 drop off side: right
 drop off height: 2,010 mm (standard)
 2,650 mm (extended conveyor belt)

Conveyor belt beneath double drum, Fine fraction

belt width: 800 mm
 belt length: 4,500 mm

2 fractions:

fine fraction: 2 - 80 mm, on demand
 coarse fraction: ex 170 mm (standard)
 3rd fraction: optional by extension

Screen material:

sand, saw dust, wood chips, compost, soil, glass, coal and cinder, construction waste and recycling materials, stones and gravel sand



MULTI SCREEN® MS3200

TECHNICAL DESCRIPTION 2

Chassis options:



On wheels (standard)



Track drive
(requires remote control Maxi)



On skids



Hook lift

Power:

electric drive (32A)
approx. 12,7 kW / 15,9 kVA (standard)
optional diesel-power-generator 17 kVA
(not included in the basic price)

Additional hydraulic options:

Standard conveyor belt
Rear conveyor belt for coarse fraction
extended conveyor belt for fine fraction
extended conveyor belt for coarse fraction

Weight:

approx. 7,600 kg
(standard equipped machine)

Hitch:

height adjustable,
drawbar eye Ø 40 mm or Ø 50 mm

Dimensions:

Transportation:

Standard	ext. conveyor belt
length: 9.200 mm	9.200 mm
height: 3.600 mm	3.640 mm
width: 2.450 mm	2.450 mm

Operation:

Standard	ext. conveyor belt
length: 9.200 mm	9.200 mm
height: 3.200 mm	3.200 mm
width: 6.650 mm	10.136 mm

Capacity:

up to 60 m³/hour,
depending on condition of
material, mesh size and feeding

Colour / Coats:

polyurethane one-coat topcoat
silo, engine cover and side covers: RAL 6001 green
chassis, screening drum: RAL 7022 umbra grey
conveyor belt frame: hot galvanized



MULTI SCREEN® MS3200

DIMENSIONS STANDARD EQUIPPED

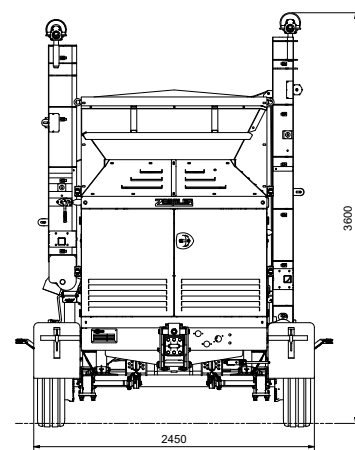
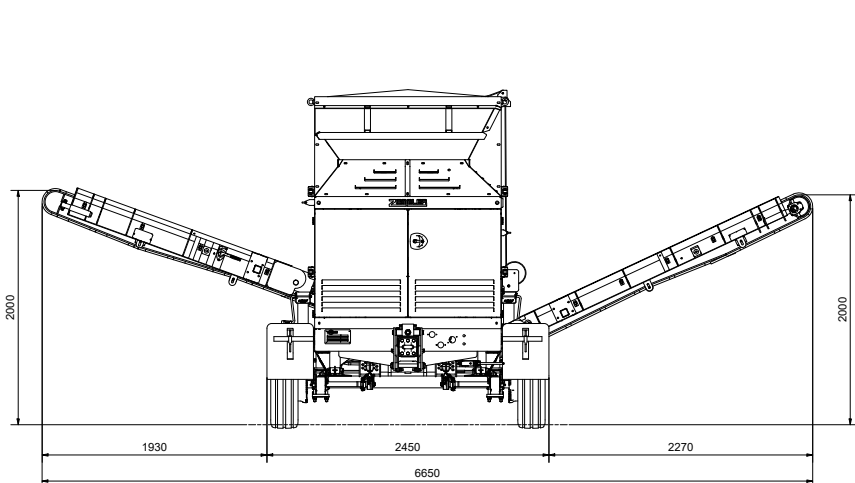
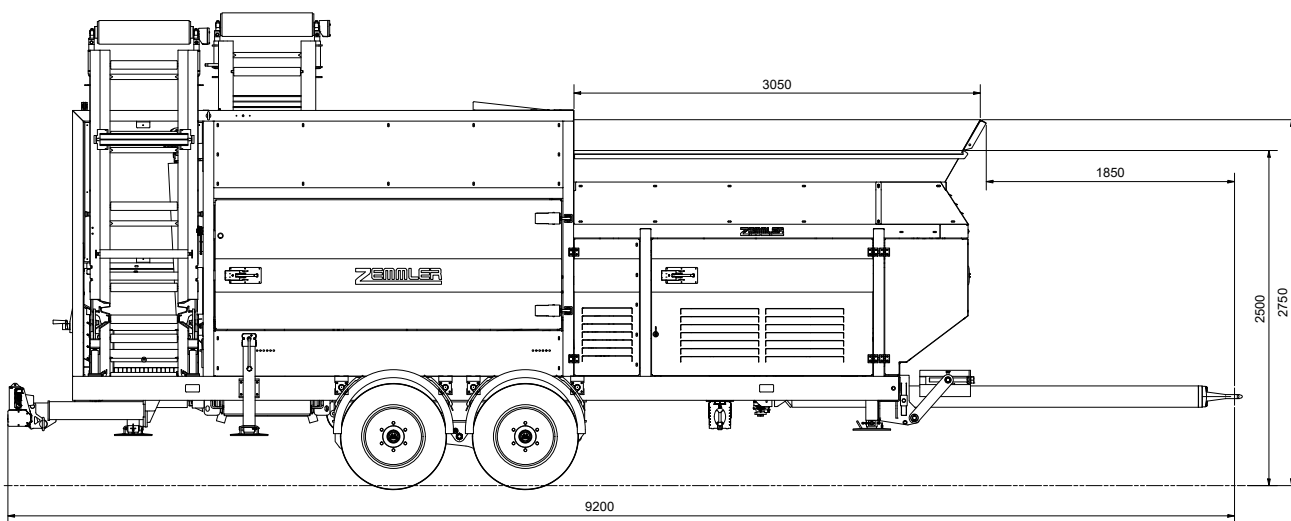



MULTI SCREEN® MS3200

OPTION REAR CONVEYOR BELT FOR THE COARSE FRACTION
/ EXTENSION FOR FEEDER HOPPER

